

BELAZ-7513B mining dump truck

with payload capacity of 130-136 tonnes

It's designed for transportation of rock in difficult mining conditions of deep mines, in open pit mining of mineral deposits on roads under various climatic operating conditions (at ambient temperature from -50 to +50 °C).



Engine

Rated power @ 1900 rpm, kW (hp)	1193(1600)
Maximum torque @ 1500 rpm, N.m	7612
Number of cylinders	12
Cylinders displacement, l	48,8
Cylinder diameter, mm	165
Piston stroke, mm	190
Specific fuel consumption at rated power, g/kW hr	201
Air cleaning is performed by three-stage filters with dry-type elements. Engine exhaust expulsion is performed through two exhaust manifolds and body.	
Circulating lubrication system is pressurized and designed with "wet" sump. Double-loop fluid cooling system with forced circulation.	
Fluid preheating system.	
Pneumatic starter starting system.	
Electric equipment system voltage, V	24

Electric drive

AC KTE-136 drive with traction alternator, two traction motors, motorized wheels differential-type double-row planetary reduction units, control cabinet and dynamic braking unit, adjustment units and control devices.	
Transmission ratio	30,36
Maximum travel speed, km/h	64

Control cabinet	ShU-136
Traction alternator	GST-800
Traction motor	TAD-5

Suspension

Suspension is conventional for front and rear wheels. Cylinders are pneumohydraulic (nitrogen and oil). Two cylinders are on the front axle and two cylinders are on the rear axle.	
Cylinder piston stroke, mm	
- front	320
- rear	290

Steering

Hydrostatic steering with fluid amplifier and drive from variable-flow pump. The steering consists of pump-dosing unit, two double-action hydraulic cylinders and trapezium. Pneumatic-hydraulic accumulator emergency drive.	
Steering angle, degree	42
Turning radius, m	13
Overall turning diameter, m	28

Brakes

Service brakes are dry disk brakes with hydraulic actuator separated for front and rear wheels.	
Parking brake consists of permanently closed dry disk brakes on traction motor shafts with spring actuator and hydraulic control.	
Auxiliary brake is electrodynamic braking by traction motors with forced air cooling of brake resistors (17EM137).	
Emergency brake uses parking brake and operable circuit of wheel brakes.	

Hydraulic drive

Hydraulic system is combined for body dumping gear, steering, actuator of brakes. The system consists of oil tank, variable-capacity axial-piston pump with cardan drive from traction alternator shaft, fluid distribution equipment on the basis of three-position spool hydraulic distributor with safety valves and high-pressure hoses.	
Electrohydraulic control. Diagnostic socket is provided. The system meets EH474-1, EH474-6 and EH853 safety requirements.	
Two three-stage hydraulic cylinders with final stage of double action. Automatic lowering at start of motion and limitation of maximum body lifting angle.	
Body lifting time, s	20
Body lowering time, s	18

Body

Welded bucket-type body with rops, engine exhaust heating, device for mechanical fixing in raised position, rock-fenders and rock-ejectors.

Body capacity, m³:

struck	heaped 2:1
45,5	71,2 (standard)
50,1	75,5 (option)
55,0	80,0 (option)
59,6	84,0 (option)

Frame

Frame is welded of high-strength low-alloy steel and equipped with box-section variable-height side-members interconnected by cross-members.



Tires

Tubeless air tires with quarry tread pattern.

Tire designation	33.00-51; 33.00R51
Inflation pressure, MPa	0.62; 0.7
Rim designation	24.00-51/5.0

Cab

Two-man cab with air-sprung adjustable driver seat, ROPS safety system.

The cab meets requirements of standards that specify permissible levels of in-cab noise, vibration, content of hazardous substances and dust.

In-cab noise level is not more than 80 dB(A).

Local vibration level is not more than 126 dB(A).

Overall vibration level is not more than 115 dB(A).

Special equipment

- Fire-fighting system (standard)
- Heating and conditioning unit (standard)
- Starting preheater (standard)
- Automatic lubrication system (optional)
- Loading control system (optional)
- Telemetering tire-pressure monitoring system (optional)
- Body floor lining (optional)
- Attention device of approach to high-voltage line (optional)
- Air purification system (optional)

Overall dimensions, mm*

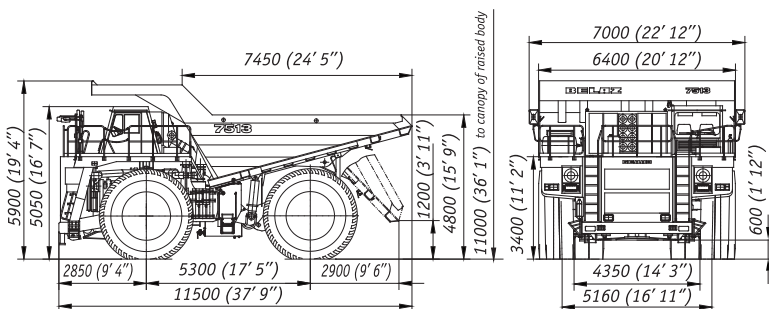

*Overall dimensions are specified for dump truck with standard options

Weight

Maximum payload capacity of the dump truck equipped with:

- diagonal tires 33.00-51, kg	128600
- radial tires 33.00R51, kg	134600
Operating weight, kg	108500

Gross weight of the dump truck equipped with:

- diagonal tires 33.00-51, kg	237100
- radial tires 33.00R51, kg	243100

Dump truck weight distribution on axles, %:

	unladen	laden
- front	50,9	33,0
- rear	49,1	67,0

Capacities, l

Fuel tank	1900
Engine cooling system	410
Engine lubrication system	195
Oil tank	490
Reduction units of motorized wheels	92 (46x2)
Suspension cylinders:	
- front	33,8 (16,9x2)
- rear	57,4 (28,7x2)

Propulsion and Retarding

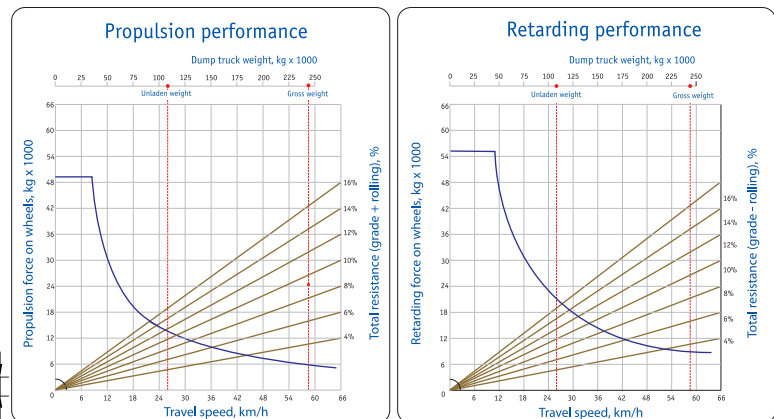

BELAZ

OJSC "BELAZ" — Management Company of Holding "BELAZ-HOLDING"
 40 let Oktyabrya str. 4, 222160, Zhodino, Minsk region, Republic of Belarus
 phone: +375 1775 3-27-82, 3-26-23, 3-37-37, fax: +375 1775 7-01-37
 e-mail: office@belaz.minsk.by, marketing@belaz.minsk.by,
 export@belaz.minsk.by
www.belaz.by